

# \*TB 9-6625-862-35

DEPARTMENT OF THE ARMY TECHNICAL BULLETIN

## CALIBRATION PROCEDURE FOR AUDIO OSCILLATORS, TS-421 ( )/U (DATA ROYAL, MODEL F370A) AND SIGNAL GENERATOR HEWLETT-PACKARD, MODEL 205AG

Headquarters, Department of the Army, Washington, DC

7 May 2004

*Distribution Statement A: Approved for public release; distribution is unlimited.*

### REPORTING OF ERRORS AND RECOMMENDING IMPROVEMENTS

You can improve this manual. If you find any mistakes or if you know of a way to improve these procedures, please let us know. Mail your letter or DA Form 2028 (Recommended Changes to Publications and Blank Forms) directly to: Commander, US Army Aviation and Missile Command, AMSAM-MMC-MA-NP, Redstone Arsenal, AL 35898-5000. A reply will be furnished to you. You may also provide DA Form 2028 information to AMCOM via e-mail, fax, or the World Wide Web. Our fax number is DSN 788-6546 or Commercial 256-842-6546. Our e-mail address is [2028@redstone.army.mil](mailto:2028@redstone.army.mil). Instructions for sending an electronic 2028 may be found at the back of this manual. For the World Wide Web, use <https://amcom2028.redstone.army.mil>.

SECTION		Paragraph	Page
I.	IDENTIFICATION AND DESCRIPTION		
	Test instrument identification .....	1	2
	Forms, records, and reports.....	2	2
	Calibration description .....	3	2
II.	EQUIPMENT REQUIREMENTS		
	Equipment required .....	4	3
	Accessories required.....	5	3
III.	CALIBRATION PROCESS		
	Preliminary instructions.....	6	3
	Equipment setup .....	7	4
	Frequency and stability .....	8	5
	Output distortion.....	9	8
	Output level meter and attenuation .....	10	9
	Output level frequency response .....	11	10
	Input level meter .....	12	11
	Input attenuation .....	13	12
	Final procedure.....	14	12

\*This technical bulletin supersedes TB 9-6625-862-35, 3 July 1987, including all changes.

**SECTION I  
IDENTIFICATION AND DESCRIPTION**

**1. Test Instrument Identification.** This bulletin provides instructions for the calibration of Audio Oscillators, TS-421( )/U (Data Royal, Model F370A); and Signal Generator, Hewlett-Packard, Model 205AG. The manufacturers' manuals and TM 11-6625-355-15-1 were used as the prime data sources in compiling these instructions. The equipment being calibrated will be referred to as the TI (test instrument) throughout this bulletin.

**a. Model Variations.** Variations are described in text.

**b. Time and Technique.** The time required for this calibration is approximately 2 hours, using the dc and low frequency technique.

**2. Forms, Records, and Reports**

**a.** Forms, records, and reports required for calibration personnel at all levels are prescribed by TB 750-25.

**b.** Adjustments to be reported are designated (R) at the end of the sentence in which they appear. When adjustments are in tables, the (R) follows the designated adjustment. Report only those adjustments made and designated with (R).

**3. Calibration Description.** TI parameters and performance specifications which pertain to this calibration are listed in table 1.

Table 1. Calibration Description

Test instrument parameters	Performance specifications
Line voltage	115 V ac, $\pm 10\%$ , 60 Hz
Frequency	Range: 20 Hz to 20 kHz Dial accuracy: $\pm 2\%$
Frequency response	Range: 20 Hz to 20 kHz Accuracy: $\pm 1$ dB from 20 Hz to 20 kHz at output levels < + 30 dBm w/output meter reading held at + 37 dB $\pm 1.5$ dB from 20 Hz to 20 kHz at output levels $\geq + 30$ dBm w/output meter held at + 37 dB (reference 1 kHz)
Distortion	< 1% at frequencies above 30 Hz
Input meter	Range: -5 to +8 dBm (0 to 2 V rms) Accuracy: $\pm 5\%$ of FS
Input attenuator	Range: 0 to 40 dB Accuracy: $\pm 0.1$ dB
Output meter	Range: 0 to 65 V ac at 600 $\Omega$ Accuracy: $\pm 5\%$
Output attenuator 10 dB steps	Range: 0 to 110 dB Accuracy: $\pm 0.5$ dB, 0 to 80 dB at 1 kHz $\pm 1.5$ dB, 90 to 100 dB at 1 kHz $\pm 2.5$ dB, 0 to 100 dB at 20 kHz
1 dB steps	$\pm 0.25$ dB, 0 to 10 dB at 20 kHz

**SECTION II  
EQUIPMENT REQUIREMENTS**

**4. Equipment Required.** Table 2 identifies the specific equipment to be used in this calibration procedure. This equipment is issued with Secondary Transfer Calibration Standards Set AN/GSM-286; AN/GSM-287 or AN/GSM-705. Alternate items may be used by the calibrating activity. The items selected must be verified to perform satisfactorily prior to use and must bear evidence of current calibration. The equipment must meet or exceed the minimum use specifications listed in table 2. The accuracies listed in table 2 provide a four-to-one ratio between the standard and TI. Where the four-to-one ratio cannot be met, the actual accuracy of the equipment selected is shown in parenthesis.

**5. Accessories Required.** The accessories required for this calibration are common usage accessories issued as indicated in paragraph 4 above, and are not listed in this calibration procedure.

Table 2. Minimum Specifications of Equipment Required

Common name	Minimum use specifications	Manufacturer and model (part number)
AUDIO ANALYZER	Range: 35 Hz to 20 kHz Distortion: < 1%	Boonton, Model 1121 (1121)
AUTOTRANSFORMER	Range: 105 to 125 V ac Accuracy: 1%	General Radio, Type W10MT3AS3 (7910809), or Ridge, Model 9020A (9020A), or Ridge, Model 9020F (9020F)
FREQUENCY COUNTER	Range: 20 Hz to 21 kHz Accuracy: $\pm 0.5\%$	Fluke, Model PM6681/656 (PM6681/656)
MULTIMETER	Range: 0.46 mV to 79 V Accuracy: $\pm 0.29\%$	Fluke, Model 8840A/AF-05/09 (AN/GSM-64D)
STEP ATTENUATOR	Range: 40 dB Voltage: 50 V	Tech Laboratories, Model C-8756 (MIS-35949)

**SECTION III  
CALIBRATION PROCESS**

**6. Preliminary Instructions**

**a.** The instructions outlined in paragraphs 6 and 7 are preparatory to the calibration process. Personnel should become familiar with the entire bulletin before beginning the calibration.

**b.** Items of equipment used in this procedure are referenced within the text by common name as listed in table 2.

## **TB 9-6625-862-35**

**c.** Unless otherwise specified, verify the result of each test and, whenever the test requirement is not met, take corrective action before continuing with the calibration. Adjustments required to calibrate the TI are included in this procedure. Additional maintenance information is contained in the manufacturers' manuals and TM 11-6625-355-15-1 for this TI.

**d.** Unless otherwise specified, all controls and control settings refer to the TI.

### **7. Equipment Setup**

#### **WARNING**

HIGH VOLTAGE is used or exposed during the performance of this calibration. DEATH ON CONTACT may result if personnel fail to observe safety precautions. REDUCE OUTPUT(S) to minimum after each step within the performance checks where applicable.

- a.** Remove protective cover from TI.
- b.** Connect TI to autotransformer.
- c.** Connect autotransformer to a 115 V ac source and adjust for a 115 V ac output.
- d.** Connect shorting bar between TI lower **OUTPUT** and ground (**GND** on some models) connectors.
- e.** Position controls as listed in (1) through (7) below:
  - (1) **OUTPUT ATTENUATOR (DB) (OUTPUT DB) 0 to 10** switch to **0**.
  - (2) **OUTPUT ATTENUATOR (DB) (OUTPUT DB) 0 to 100** switch to **0**.
  - (3) **LOAD** switch to **OFF**.
  - (4) **IMPEDANCE** switch to **600**.
  - (5) **FREQUENCY RANGE** switch to **X10**.
  - (6) **FREQUENCY** dial to **20**.
  - (7) **AMPLITUDE (OUTPUT)** to **0**.
- f.** Energize and allow 30 minutes for warm-up and stabilization.

**8. Frequency and Stability**

**a. Performance Check**

(1) Connect TI **OUTPUT** terminals to multimeter and frequency counter using step attenuator.

(2) Set step attenuator to 40 dB.

(3) Set frequency counter impedance to 1 mΩ.

(4) Adjust **AMPLITUDE (OUTPUT)** control for a 50 V indication on multimeter. If frequency counter does not indicate between 196 and 204 Hz, perform **b** below.

(5) Vary autotransformer output between 105 and 125 V ac. If frequency indication does not remain between 196 and 204 Hz, perform **b** below.

(6) Adjust autotransformer output to 115 V ac.

(7) Set **FREQUENCY** dial to settings listed in table 3. If frequency counter indications are not within limits specified, perform **b** (1) through (8) below.

Table 3. X10 Frequency Range Check

FREQUENCY dial settings	Frequency counter indications (Hz)	
	Min	Max
25	245	255
40	392	408
70	686	714
100	980	1020
160	1568	1632
200	1960	2040

(8) Set **FREQUENCY RANGE** switch and **FREQUENCY** dial to settings listed in table 4. If frequency counter does not indicate within limits specified, perform **b** (9) through (12) below.

Table 4. X1 and X100 Frequency Range Check

Test instrument		Frequency counter indications (Hz)	
FREQUENCY RANGE switch settings	FREQUENCY dial settings	Min	Max
X100	20	1960	2040
X100	30	2940	3060
X100	50	4900	5100
X100	100	9800	10,200
X100	200	19,600	20,400
X1	200	196	204
X1	100	98	102
X1	50	49	51
X1	20	19.6	20.4

**TB 9-6625-862-35**

**b. Adjustments**

(1) (For models with calibrating dot or extra line at one end or other on **FREQUENCY** dial.) Turn **FREQUENCY** dial to bring calibrating dot under the indicator hairline. If necessary, loosen setscrews and slip dial on shaft for proper alignment. Tighten setscrews.

**NOTE**

When only C1 and C22 (C10 and C12 for TS-421C/U and model F370A) are provided, perform (7) below only.

- (2) Turn **FREQUENCY** dial to **20**.
- (3) Set **AMPLITUDE (OUTPUT)** control to 50 V indication on multimeter.
- (4) Change dial setting to 200.
- (5) Use adjustments below for  $\pm 2$  V and 2000 Hz  $\pm 2\%$ .

**NOTE**

TI range adjustments (figs. 1, 2, and 3) exist in combinations as listed in (a) through (e) below for different models:

- (a) Adjust C1 and C22 for best compromise (interact for both frequency and amplitude).
  - (b) C1, R7, R8, and R9.
  - (c) C2, R7, R8, and R9.
  - (d) C1, C22, R7, and R9.
  - (e) C10 and C12 on TS-421C/U and model F370A (interact for both frequency and amplitude).
- (6) Adjust R8 (fig. 2) for a 200 Hz indication on frequency counter (R).
- (7) Turn **FREQUENCY** dial to **200** and adjust either C1 or C2 (C10 and C12 on TS-421C/U and model F370A) as applicable for a 2000 Hz indication on frequency counter. If provided, adjust both C1 and C22 (C10 and C12 for TS-421C/U and model F370A) for best compromise between frequency counter indication of 2000 Hz and multimeter indication of 50 V (R).
- (8) Repeat a (1) through (7) above.
- (9) Set **FREQUENCY RANGE** switch to **X100** and turn **FREQUENCY** dial to **20**.

**NOTE**

When only C1 and C22 (C10 and C12 for TS-421C/U and model F370A) are provided, no adjustments can be made.

- (10) Adjust R7 (fig. 2) for a 2000 Hz indication on frequency counter (R).
- (11) Set **FREQUENCY RANGE** switch to **X1** and turn **FREQUENCY** dial to **100**.
- (12) Adjust R9 (fig. 2) for a 100 Hz indication on frequency counter (R).

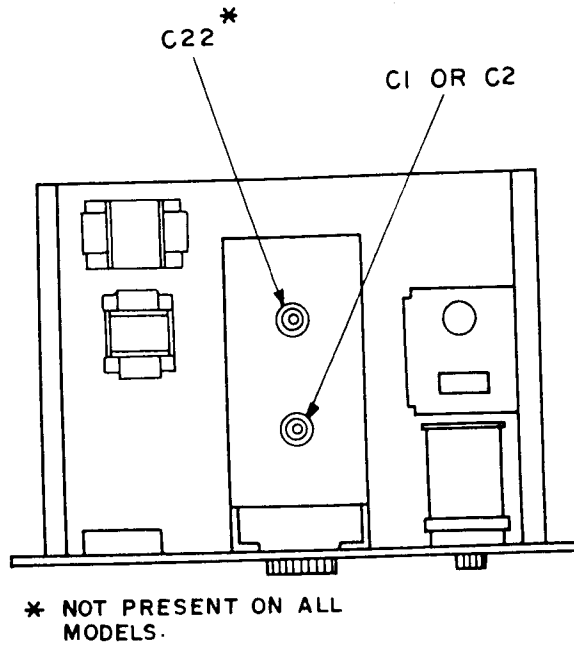

Figure 1. Test instrument - top view.

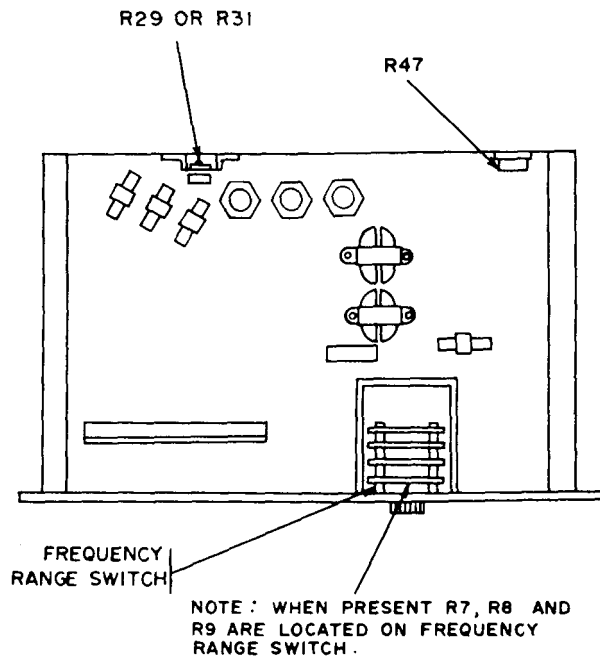

Figure 2. Test instrument - bottom view.

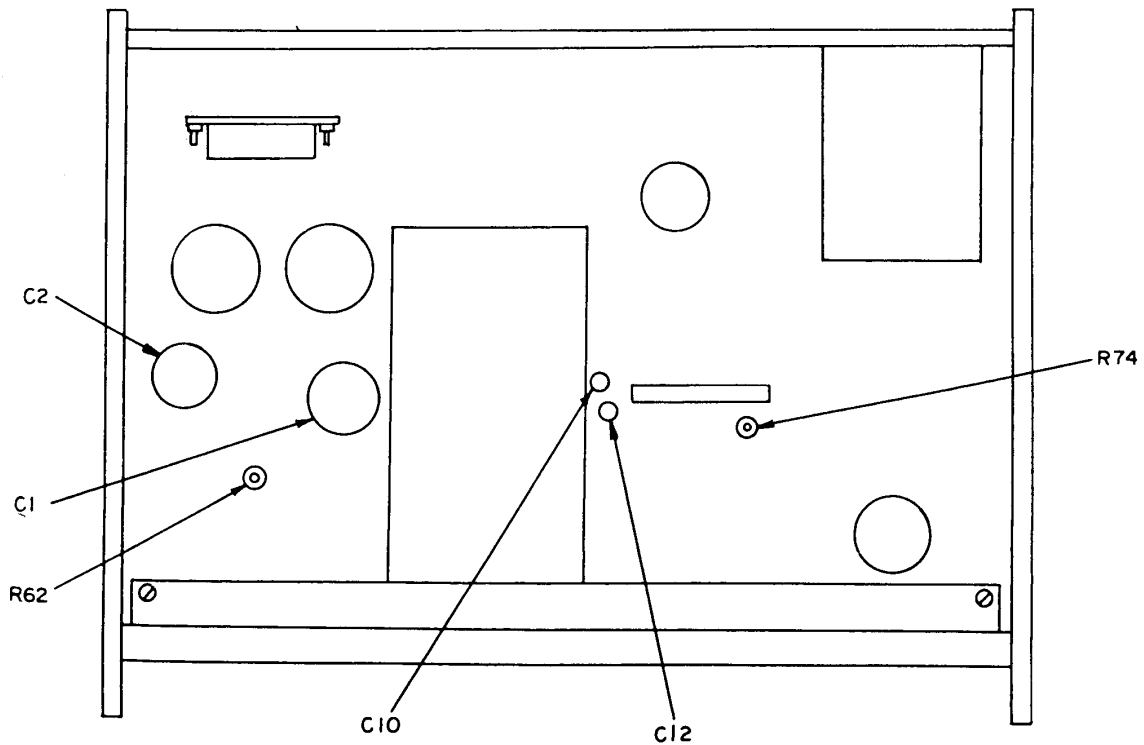

Figure 3. Test instrument - (TS-421C/U and model F370A).

## 9. Output Distortion

### a. Performance Check

- (1) Adjust **AMPLITUDE (OUTPUT)** control to minimum.
- (2) Connect **OUTPUT** connector to audio analyzer connector.
- (3) **LOAD** switch to **ON**.
- (4) Set **FREQUENCY RANGE** switch to **X10** and turn **FREQUENCY** dial to **50**.
- (5) Adjust **AMPLITUDE (OUTPUT)** control for a + 37dB indication on upper scale of **OUTPUT LEVEL** meter. Audio analyzer will indicate less than one percent distortion.
- (6) Repeat technique of (4) and (5) above, using **FREQUENCY RANGE** switch and **FREQUENCY** dial settings listed in table 5. Audio analyzer will indicate less than one percent distortion.



Table 5. Output Distortion Check

FREQUENCY RANGE switch settings	FREQUENCY dial settings
X10	35
X10	100
X10	200
X1	35
X1	50
X1	100
X1	200
X100	35
X100	100
X100	200

b. Adjustments. No adjustments can be made.

10. Output Level Meter and Attenuation

a. Performance Check

(1) Adjust **AMPLITUDE (OUTPUT)** control to 0 (zero) and adjust meter pointer to 0 using 0 adjustment screw on the meter.

(2) Set **FREQUENCY RANGE** switch to **X1** and turn **FREQUENCY** dial to **100**.

(3) Connect **OUTPUT** to multimeter input connector.

(4) Adjust **AMPLITUDE (OUTPUT)** control for + 37dB indication on **OUTPUT LEVEL** meter. If multimeter does not indicate between 52.12 and 57.6 V ac, perform **b** below.

(5) Set **FREQUENCY RANGE** switch to **X10**.

(6) Adjust **AMPLITUDE** control for a 54.86 V indication on multimeter. Record **OUTPUT LEVEL** meter indication.

(7) While maintaining **OUTPUT LEVEL** meter indication recorded in (6) above, set **OUTPUT ATTENUATOR (DB) (OUTPUT DB) 0** to **100** switch to settings listed in table 6. Multimeter indications will be within limits specified.

Table 6. Output Attenuator Check 0 to 100 dB

Test instrument <b>OUTPUT ATTENUATOR (DB)</b> switch settings	Multimeter indications (V or (dB))			
	Min		Max	
10	16.38	(26.5)	18.38	(27.5)
20	5.18	(16.5)	5.81	(17.5)
30	1.63	(6.5)	1.83	(7.5)
40	0.518	(-3.5)	0.581	(-2.5)
50	0.63	(-13.5)	0.183	(-12.5)
60	0.0518	(-23.5)	0.0581	(-22.5)
70	0.0163	(-33.5)	0.0183	(-32.5)
80	0.00518	(-43.5)	0.00581	(-42.5)
90	0.00145	(-54.5)	0.00206	(-51.5)
100	0.00046	(-64.5)	0.00065	(-61.5)

**TB 9-6625-862-35**

(8) Set **OUTPUT ATTENUATOR (DB) (OUTPUT DB) 0 to 100** switch to **20**.

(9) Set **FREQUENCY RANGE** switch to **X100** and turn **FREQUENCY** dial to **200**.

(10) Adjust **AMPLITUDE (OUTPUT)** control for a 5.0 V indication on multimeter. Record **OUTPUT LEVEL** meter indication.

(11) While maintaining **OUTPUT LEVEL** meter indication recorded in (10) above, set **OUTPUT ATTENUATOR (DB) (OUTPUT DB) 0 to 10** switch to settings listed in table 7. Multimeter indications will be within limits specified.

Table 7. Output Attenuator Check 0 to 10 dB

Test instrument <b>OUTPUT ATTENUATOR (DB) switch settings</b>	Multimeter indications (V or (dB))			
	Min		Max	
1	4.32	(-0.75)	4.58	(-1.25)
2	3.85	(-1.75)	4.08	(-2.25)
3	3.43	(-2.75)	3.64	(-3.25)
4	3.06	(-3.75)	3.24	(-4.25)
5	2.73	(-4.75)	2.89	(-5.25)
6	2.43	(-5.75)	2.57	(-6.75)
7	2.17	(-6.75)	2.29	(-7.25)
8	1.93	(-7.75)	2.04	(-8.25)
9	1.72	(-8.75)	1.82	(-9.25)
10	1.53	(-9.75)	1.62	(-10.25)

**b. Adjustments**

(1) Adjust **AMPLITUDE (OUTPUT)** control for a 54.86 V indication on multimeter.

(2) Adjust R29 (fig. 2) (R31 on some models) (R74 on TS-421C/U and model F370A, fig. 3) for a +37-dB indication on **OUTPUT LEVEL** meter.

**11. Output Level Frequency Response**

**a. Performance Check**

(1) Position controls as listed in (a) through (d) below:

(a) **OUTPUT ATTENUATOR (DB) (OUTPUT DB) 0 to 100** switch to **0**.

(b) **OUTPUT ATTENUATOR (DB) (OUTPUT DB) 0 to 10** switch to **6**.

(c) **FREQUENCY RANGE** switch to **X10**.

(d) **FREQUENCY** dial to **100**.

(2) Adjust **AMPLITUDE (OUTPUT)** control for a 27.483 indication on multimeter. Record **OUTPUT LEVEL** meter indication.

(3) While maintaining **OUTPUT LEVEL** meter indication recorded in (2) above, set **FREQUENCY RANGE** switch and **FREQUENCY** dial for 40 Hz, 200 Hz, 2 kHz, and 20 kHz. Multimeter indication will be between 23.12 and 32.66 V.

(4) Adjust **AMPLITUDE (OUTPUT)** control to **0**.

**b. Adjustments.** No adjustments can be made.

**12. Input Level Meter**

**a. Performance Check**

(1) Connect **INPUT** connector to **INPUT** ground connector.

(2) Adjust zero adjustment screw on **INPUT LEVEL** meter for a 0 V indication.

(3) Remove test lead from **INPUT** connectors.

(4) Position controls as listed in (a) through (g) below:

(a) **INPUT ATTENUATOR (DB) (INPUT DB)** switch to **0**.

(b) **OUTPUT ATTENUATOR (DB) (OUTPUT DB) 0 to 100** switch to **30**.

(c) **OUTPUT ATTENUATOR (DB) (OUTPUT DB) 0 to 10** switch to **6**.

(d) **LOAD** switch to **OFF**.

(e) **IMPEDANCE** switch **5000**.

(f) **FREQUENCY RANGE** switch to **X10**.

(g) **FREQUENCY** dial to **40**.

(5) Connect multimeter between **INPUT** connector and **INPUT** ground connector.

(6) Connect upper **INPUT** connector to upper **OUTPUT** connector.

(7) Adjust **AMPLITUDE (OUTPUT)** control for a 2.0 V indication on **INPUT LEVEL** meter. If multimeter does not indicate between 1.9 and 2.1 V ac, perform **b** below.

(8) Repeat technique of (7) above while adjusting **AMPLITUDE (OUTPUT)** control for **INPUT LEVEL** meter indications listed in table 8. Multimeter indications will be within limits specified.

Table 8. Input Level Meter Linearity Check

Test instrument <b>INPUT LEVEL</b> meter indications	Multimeter indications (V ac)	
	Min	Max
1.5	1.4	1.6
1.0	0.9	1.1
0.5	0.4	0.6

(9) Adjust **AMPLITUDE (OUTPUT)** control to **0**.

**b. Adjustments**

(1) Adjust **AMPLITUDE (OUTPUT)** control for a 2.0 V ac indication on multimeter.

(2) Adjust R47 (fig. 2) (R62 (fig. 3) on TS-421C/U and model F370A) for a 2.0 V ac indication on **INPUT LEVEL** meter (R).

**13. Input Attenuation**

**a. Performance Check**

- (1) Set **OUTPUT ATTENUATOR (DB) (OUTPUT DB) 0 to 10** switch to **0**.
- (2) Adjust **AMPLITUDE (OUTPUT)** control for a 0.775 V ac indication on multimeter. Record **INPUT LEVEL** meter indications.
- (3) Set **INPUT ATTENUATOR (DB) (INPUT DB)** switch to settings listed in table 9, while adjusting **AMPLITUDE** control setting **OUTPUT ATTENUATOR (DB) (OUTPUT DB)** switches as required for **INPUT LEVEL** meter indication recorded in (2) above. Multimeter indications will be within limits specified.

**b. Adjustments.** No adjustments can be made.

Table 9. Input Attenuator Check

Test instrument <b>INPUT ATTENUATOR (DB)</b> switch settings	Multimeter indications (V or (DB))			
	Min		Max	
5	1.362	(4.9)	1.394	(5.1)
10	2.422	(9.9)	2.479	(10.1)
15	4.308	(14.9)	4.408	(15.1)
20	7.661	(19.9)	7.839	(20.1)
25	13.623	(24.1)	13.941	(25.1)
30	24.227	(29.9)	24.791	(30.1)
35	43.082	(34.9)	44.086	(35.1)
40	76.612	(39.9)	78.397	(40.1)

**14. Final Procedure**

- a.** Deenergize and disconnect all equipment.
- b.** Annotate and affix DA label/form in accordance with TB 750-25.

By Order of the Secretary of the Army:

Official:

**PETER J. SCHOOMAKER**

*General, United States Army*

*Chief of Staff*



**JOEL B. HUDSON**

*Administrative Assistant to the  
Secretary of the Army*

0407001

Distribution:

To be distributed in accordance with the initial distribution number (IDN) 342812, requirements for calibration procedure TB 9-6625-862-35.



## INSTRUCTIONS FOR SUBMITTING AN ELECTRONIC 2028

The following format must be used if submitting an electronic 2028. The subject line must be exactly the same and all fields must be included; however, only the following fields are mandatory: 1, 3, 4, 5, 6, 7, 8, 9, 10, 13, 15, 16, 17, and 27.

From: "Whomever" [whomever@redstone.army.mil](mailto:whomever@redstone.army.mil)

To: <2028@redstone.army.mil

Subject: DA Form 2028

1. **From:** Joe Smith
2. **Unit:** home
3. **Address:** 4300 Park
4. **City:** Hometown
5. **St:** MO
6. **Zip:** 77777
7. **Date Sent:** 19-OCT-93
8. **Pub no:** 55-2840-229-23
9. **Pub Title:** TM
10. **Publication Date:** 04-JUL-85
11. **Change Number:** 7
12. **Submitter Rank:** MSG
13. **Submitter FName:** Joe
14. **Submitter MName:** T
15. **Submitter LName:** Smith
16. **Submitter Phone:** 123-123-1234
17. **Problem:** 1
18. **Page:** 2
19. **Paragraph:** 3
20. **Line:** 4
21. **NSN:** 5
22. **Reference:** 6
23. **Figure:** 7
24. **Table:** 8
25. **Item:** 9
26. **Total:** 123
27. **Text**

This is the text for the problem below line 27.

